

PRODUCT SPECIFICATION SHEET

EDI MaxAir™ Diffuser with Spectrum™ Saddle Mount

MaxAir coarse bubble diffuser offers proven design and is ideal for both mixing and aeration applications

- Inverted air chamber design for uniform air release over a wide airflow range
- Full 48" air release perimeter
- High airflow capacity
- Available in 24-inch length
- Clog resistant self-purge design
- Standard open bottom and optional deflector bottom designs available
- PVC or optional CPVC construction for maximum chemical and temperature resistance vs. steel
- Rugged heavy duty construction with full 3-inch connection (stronger than stainless steel)
- Patented Spectrum diffuser mount for maximum strength and ease of installation on any pipe material
- Spectrum diffuser mount available for 3 to 8-inch pipe (metric 110, 160 mm also available)
- Simplex or duplex configuration
- Standard sizes IN STOCK for immediate shipment

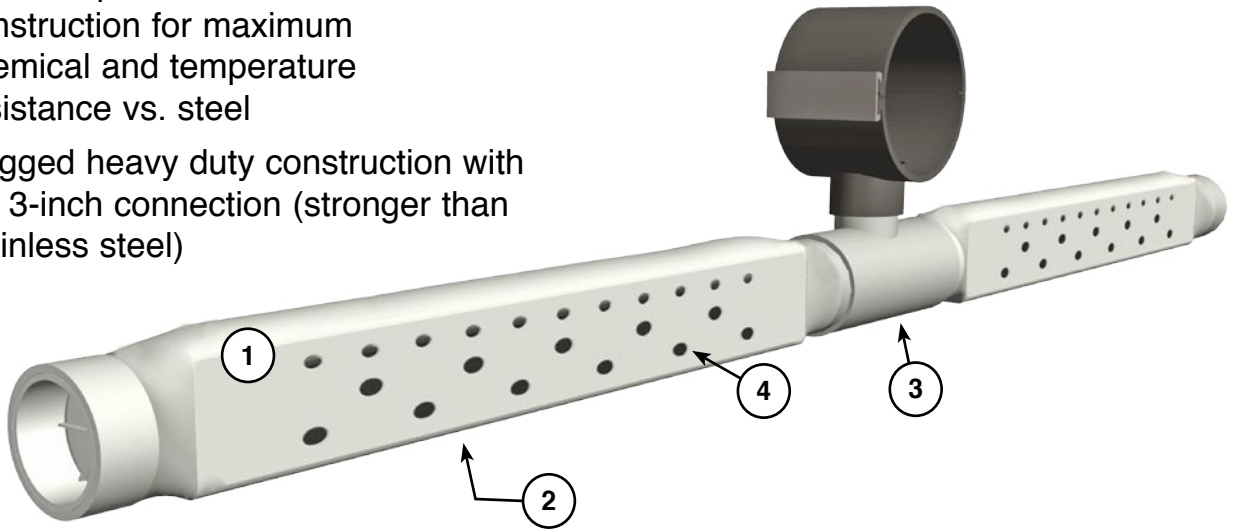

1. Diffuser Body
2. Standard Open Bottom
3. Full 3 inch Diameter Mount
4. 3 Level Air Metering Orifices



www.wastewater.com
Environmental Dynamics Incorporated

30
YEARS
1975-2005

PRODUCT SPECIFICATION SHEET

EDI MaxAir diffuser provides broad band, coarse bubble aeration for maximum mixing efficiency. The units are available in 24-inch standard lengths. The 24-inch diffuser unit provides a full 48" air release perimeter. Most importantly, the air release uniformity and mixing efficiency of the diffuser is maintained over the entire operating range of the unit.

MaxAir diffusers are ideal for the most demanding aeration and mixing applications including flow equalization, channel aeration, aerobic digesters, industrial, and mixing and scouring applications including RBC, MBR, IFAS, and MBBR.

Air distribution is achieved with fixed orifices positioned on three levels. As the air flow to the diffuser increases, the number of active orifices increases thereby minimizing the pressure required for increased airflow.

The standard unit features an open bottom design for maximum non-clog efficiency. The diffuser may be operated under a wide range of applications including intermittent and high solids applications. Optional deflector bottom design provides a mechanism to preclude entry of large particles into the diffuser and piping components.

The MaxAir diffuser is designed for long service life. All components are PVC or optional high temperature CVPC. Diffuser body attaches to air piping using a Spectrum Diffuser Mount with full 3-inch connection.

MaxAir diffusers feature the patented Spectrum Diffuser Mount. This unique mounting system clamps to the outside surface of the air supply pipe and may be installed on any pipe material. Saddle mounts are available from 3 through 8-inch pipe sizes, plus 110 mm and 160 mm metric sizes.

Patents 5,032,325 and 4,960,546

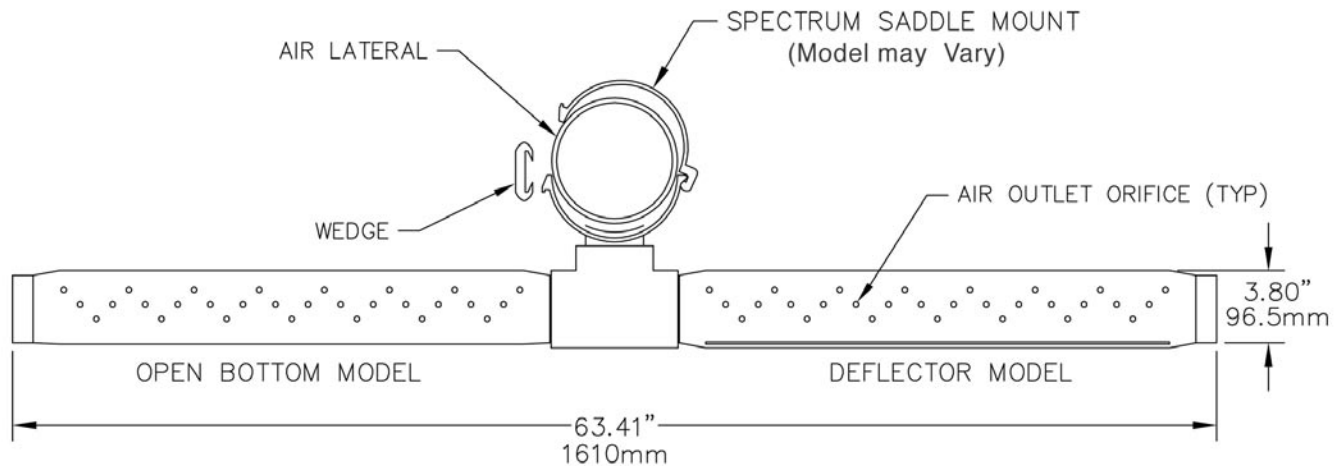

Model	Typical Airflow	Peak Design Airflow	Typical Pressure Loss Thru Unit*
Simplex	0-30 SCFM (0-48NM ³ /HR)	50 SCFM (80NM ³ /HR)	0.7-2.8inH ₂ O
Duplex	0-60 SCFM (0-95NM ³ /HR)	100 SCFM (160NM ³ /HR)	0.7-2.8inH ₂ O

* Diffuser losses only. Proper system design requires orifice installation/sizing of air supply pipe



Environmental Dynamics Inc.
5601 Paris Road Columbia, MO 65202
USA 573-474-9456

For Parts Information:
parts@wastewater.com
www.diffuserexpress.com

For System Information:
systems@wastewater.com
www.wastewater.com