

EDI Nautilus® Floatable Aeration Module

"Float-In / Float - Out" aeration modules offer installation and maintenance flexibility without draining the reactor.

- Economical solution where retrievable aeration components are desired
- Ideal for large reactors, single basin systems, or when inadequate access is available
- Simple access and inspection; single valve activates integral buoyancy chamber and raises the assembly to the water surface
- Simple maintenance; relocate floating assembly to reactor perimeter for removal or maintain in place with Nautilus II configuration
- Supports high density diffuser designs for maximum operating efficiency and aeration capacity.
- Configurable with fine or coarse bubble diffusers
- Nautilus II configuration provides full access to the diffuser assemblies allowing maintenance to be completed in place

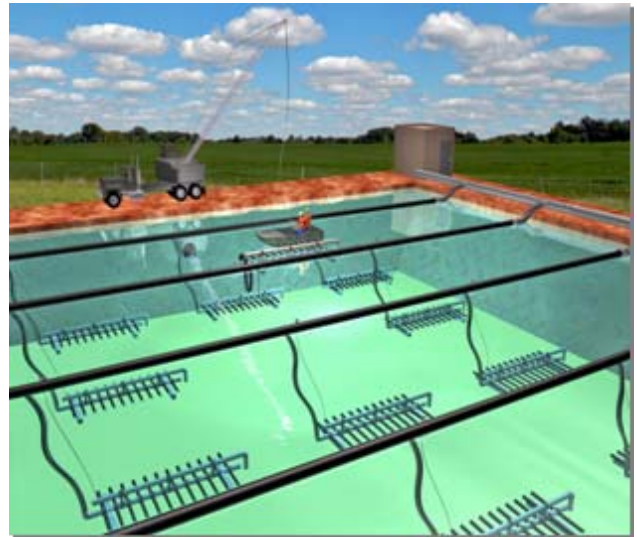

PRODUCT SPECIFICATION SHEET

Draining reactor basins to access, inspect or maintain aeration systems is a significant outage and results in a disruption in service.

EDI Nautilus® “float-in / float-out” aeration module allows aeration components to be accessed and removed from the reactor with no interruption in service or requirement to drain the reactor basin.

All aeration systems regardless of type need to be designed with access in mind. EDI Nautilus system is an economical solution when;

- operating a single reactor system,
- components cannot be accessed due to large reactor size,
- restricted access around perimeter of reactor,
- when the facility is near or at capacity, or
- tankage cannot be drained for any reason.

Individual modules are self-ballasted and are independently retrievable. Single valve activates an integral buoyancy chamber and lifts the assembly to the water surface. The floating assembly is easily relocated to the reactor perimeter for easy removal. Integral lifting points are provided. The entire assembly is removable providing complete assembly maintainability.

Optional Nautilus II configuration provides access to the diffuser components allowing diffuser maintenance to be completed insitu without a requirement to remove the assembly from the reactor.

Modules up to 20 ft (6 m) are available with EDI TrussAir™. TrussAir system feature an efficient structural truss design allowing economical materials including PVC, ABS and CPVC to be used. Stainless steel modules up to 65 ft (20 m) are available for large systems.

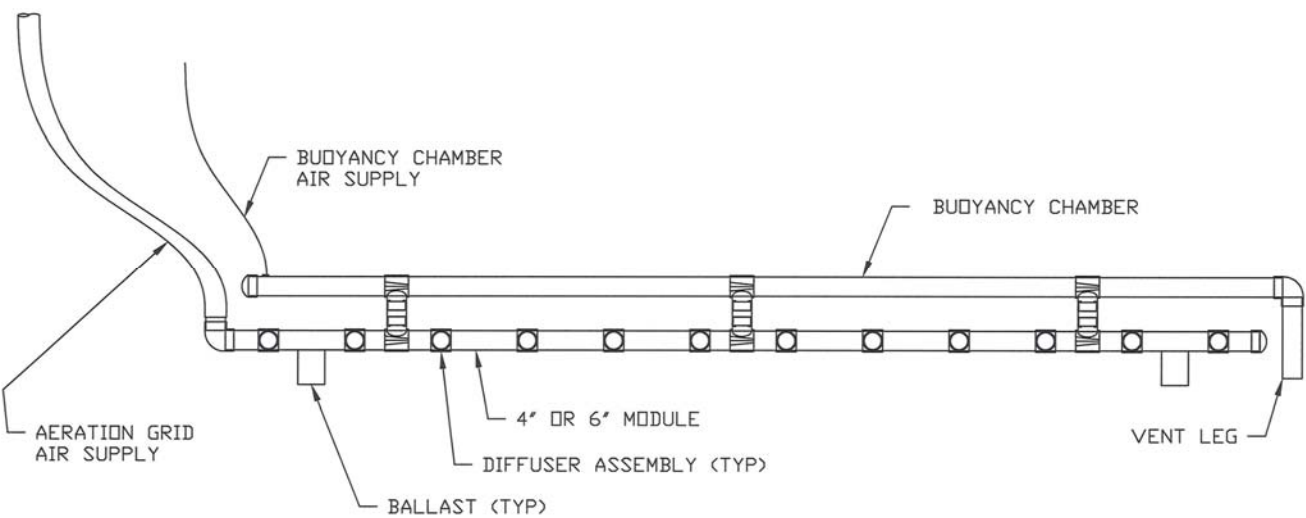

Environmental Dynamics Inc.

5601 Paris Road Columbia, MO 65202
USA +1.573.474.9456

For Parts Information
Parts@wastewater.com
www.diffuserexpress.com

For System Information
systems@wastewater.com
www.wastewater.com