

PRODUCT SPECIFICATION SHEET

EDI FlexAir[®] Disc with Spectrum[™] Saddle Mount Fine Pore Ceramic Media Technology

EDI FlexAir Disc diffuser incorporates EDI advanced technologies for superior aeration performance, flexibility, and reliability.

- Fine pore media for high oxygen transfer efficiency
- Premium quality, fused aluminum oxide media, convertible to flexible membrane as required
- Full 9-inch (230 mm) of active surface area
- Rugged, heavy-duty construction – withstands over 700 lbs (318 kgs) edge load without failure
- Glass fiber reinforced polypropylene construction for maximum chemical, temperature, and UV resistance
- Spectrum Saddle Mount provides ease of installation and maintenance
- KlicLoc[™] retainer for positive mechanical lock
- Available in 3-in and 4-in, and 90-mm and 110-mm pipe sizes for design flexibility
- Mounts on any pipe material (PVC, ABS, CPVC, SS, etc.)
- Standard units IN STOCK for immediate shipment

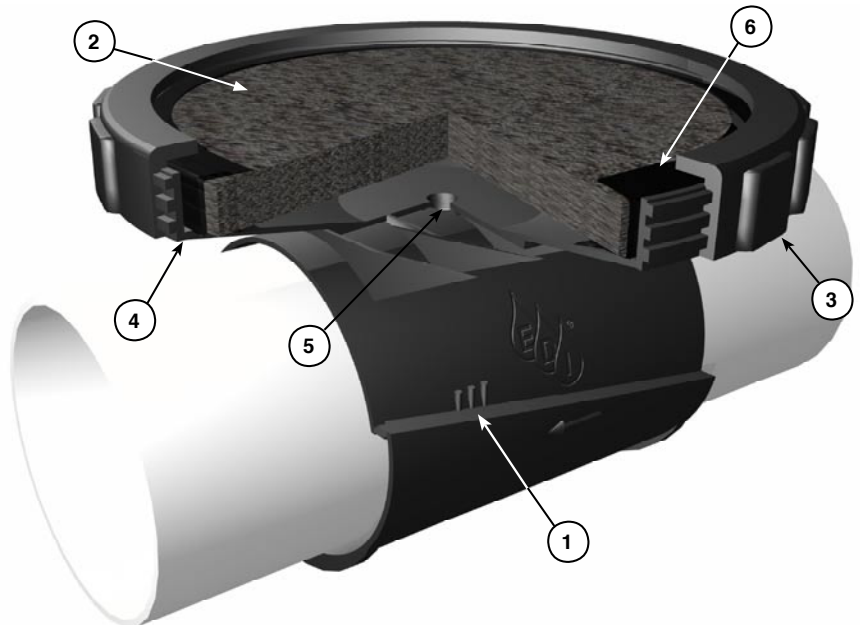

1. Saddle Mount with KlicLoc[™] Retainer
2. Ceramic Diffuser Media
3. Media Retainer Ring
4. Diffuser Body
5. Air Inlet Orifice
6. Gasket



www.wastewater.com
Environmental Dynamics Incorporated

30
YEARS
1975-2005

PRODUCT SPECIFICATION SHEET

The FlexAir® ceramic disc diffuser provides unmatched mechanical strength, operating flexibility and oxygen transfer efficiency for rigid media aeration. The innovative Spectrum Saddle Mount provides maximum mechanical integrity – up to three times the strength of conventional solvent welded or threaded mounting systems.

The FlexAir ceramic disc diffuser uses a premium quality, 0.75-inch aluminum oxide disc and full edge-sealing gasket. The media is available in a wide range of porosities for maximum application flexibility. The FlexAir ceramic disc diffuser is best suited for continuous aeration applications where maximum online service life is required. The EDI FlexAir ceramic disc diffuser allows easy conversion to flexible membrane media as required and diffusion media options (ceramic and membrane) are compatible with other 9-inch disc diffusers.

The diffuser assembly and Spectrum Saddle Mount is available in glass-fiber reinforced polypropylene for maximum performance. This material option offers greater mechanical and temperature capabilities vs. PVC or CPVC products. The Spectrum Saddle Mount is compatible with any pipe material and is available in 3 and 4-inch, and 90 and 110-mm diameter sizes. This flexibility allows the air conveyance system to be sized to match project objectives with minimum pressure loss.

The Spectrum Saddle Mount features an air inlet port that inserts into the air supply pipe and the KlicLoc™ retainer positively locks the assembly to the lateral piping. Once installed, the assembly can withstand an external perimeter load in excess of 700 pounds (318 kgs) without failure.

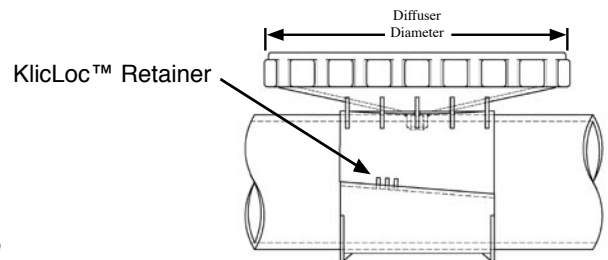
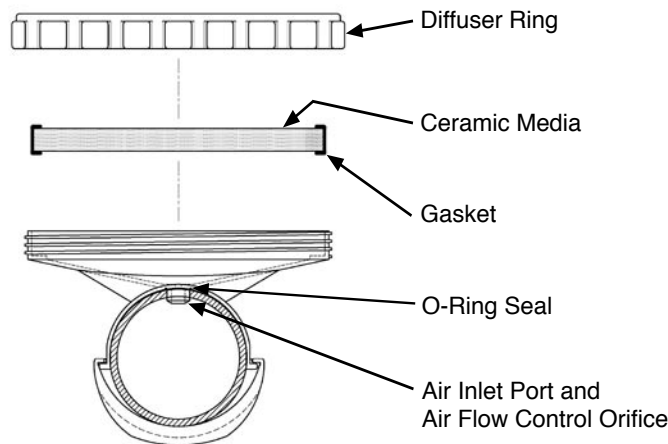

Model	Peak Airflow		Design Airflow		Design DWP		Diffuser Diameter		Active Surface Area		Dry Weight	
	scfm	sm ³ /hr	scfm	sm ³ /hr	in H ₂ O	cm H ₂ O	in	mm	ft ²	cm ²	lbs	kg
9" Disc Diffuser	5.0	8.5	1.00-3.00	1.70-5.10	6.00-11.50	15.24-29.21	10.9	276.86	0.39	366.4	6.0	2.7

*Design information based on standard permeability

*Alternate permeability available to meet the needs of specific applications.



Environmental Dynamics Inc.
5601 Paris Road Columbia, MO 65202
USA 573-474-9456

For Parts Information:
parts@wastewater.com
www.diffuserexpress.com

For System Information:
systems@wastewater.com
www.wastewater.com