

PRODUCT SPECIFICATION SHEET

EDI Ceramic Disc with Spectrum™ Saddle Mount Fine Pore Ceramic Media Technology

EDI Disc diffusers incorporate advanced technologies for superior aeration performance, flexibility, and reliability.

- Fine pore media for high oxygen transfer efficiency
- Premium quality, fused aluminum oxide media, convertible to flexible membrane as required
- Full 9 inch (230 mm) of active surface area
- Rugged, heavy-duty construction – withstands over 700 lb (320 kg) edge load without failure
- Glass fiber reinforced polypropylene construction for maximum chemical, temperature, and UV resistance
- Spectrum™ Saddle Mount provides ease of installation and maintenance
- KlicLoc™ retainer for positive mechanical lock
- Available in 3 inch and 4 inch, and 90 mm and 110 mm pipe sizes for design flexibility
- Mounts on any pipe material (PVC, ABS, CPVC, SS, etc...)
- Standard units IN STOCK for immediate shipment
- Convertable from ceramic to membrane

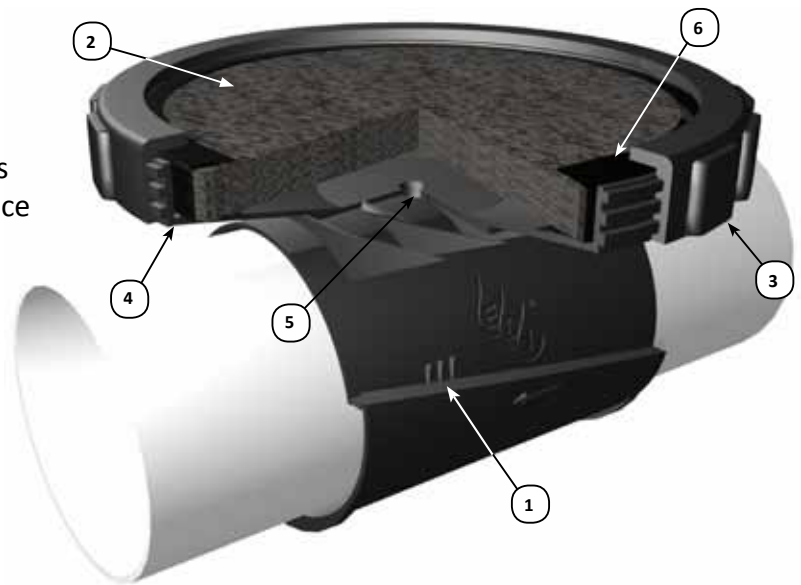

- | | |
|---------------------------------------|----------------------|
| 1. Saddle Mount with KlicLoc Retainer | 4. Diffuser Body |
| 2. Ceramic Diffuser Media | 5. Air Inlet Orifice |
| 3. Media Retainer Ring | 6. Sealing Gasket |



PRODUCT SPECIFICATION SHEET

The EDI ceramic disc diffuser provides unmatched mechanical strength, operating flexibility and oxygen transfer efficiency for rigid media aeration. The innovative Spectrum™ Saddle Mount provides maximum mechanical integrity – up to three times the strength of conventional solvent welded or threaded mounting systems.

The EDI ceramic disc diffuser uses a premium quality, 3/4 inch aluminum oxide disc and full edge-sealing gasket. The media is available in a wide range of porosities for maximum application flexibility. The FlexAir® ceramic disc diffuser is best suited for continuous aeration applications where maximum online service life is required. The EDI ceramic disc diffuser allows easy conversion to flexible membrane media as required and diffusion media options (ceramic and membrane) are compatible with other 9 inch disc diffusers.

The diffuser assembly and Spectrum Saddle Mount is available in glass-fiber reinforced polypropylene for maximum performance. This material option offers greater mechanical and temperature capabilities versus PVC or CPVC products. The Spectrum Saddle Mount is compatible with any pipe material and is available in 3 inch, 4 inch, 90 mm, and 110 mm diameter sizes. This flexibility allows the air conveyance system to be sized to match project objectives with minimum pressure loss.

The Spectrum Saddle Mount features an air inlet port that inserts into the air supply pipe and the KlicLoc™ retainer positively locks the assembly to the lateral piping. Once installed, the assembly can withstand an external perimeter load in excess of 700 lb (320 kg) without failure.

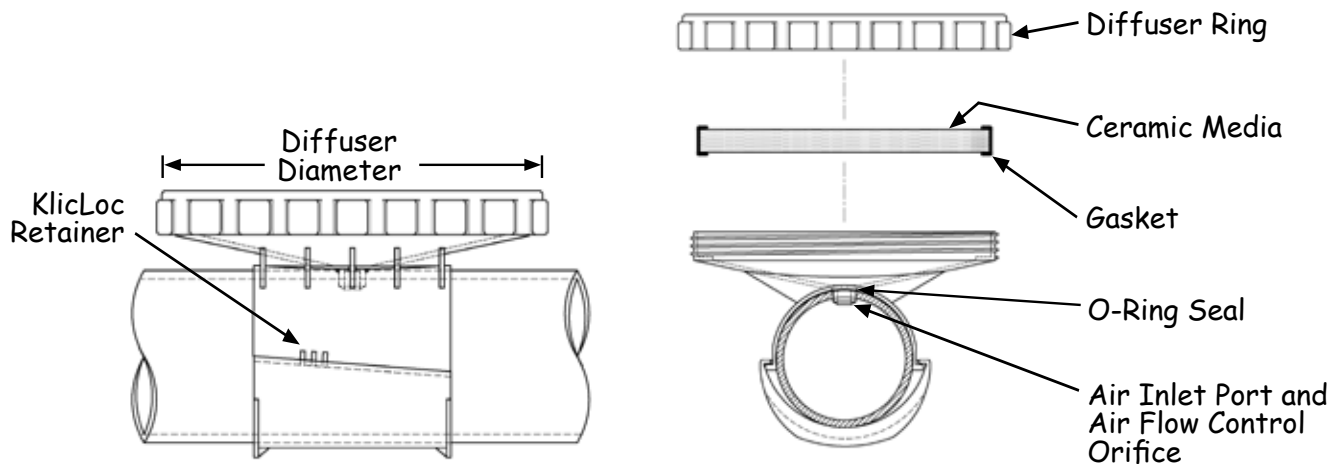

Diffuser Type	Design Airflow		Overall Diameter		Active Surface Area		Dry Weight		Net Operating Buoyancy	
	scfm	m ³ _N /h	in	mm	ft ²	m ²	lb	kg	lb	kg
9" Ceramic	0-10.0	0-16	10.9	277	0.41	0.038	5.6	2.6	-4.0	-1.8

- Optimum oxygen transfer efficiency is achieved when operating in the middle to low end of the airflow range. The approximate operating pressure of the diffuser at the mid-range is 13 to 16 inches (3.2-4.0 kPa).
- Operating the unit at the high end of the range will result in reduced performance and increased operating pressure. Use the maximum airflow value for short term operations such as peak loads or system maintenance.



Environmental Dynamics International

5601 Paris Road • Columbia, MO 65202 USA
+1 877.EDI.AIR8 (334.2478) +1 573.474.9456

For Parts Information:
parts@wastewater.com
www.diffuserexpress.com

For System Information:
systems@wastewater.com
www.wastewater.com