

PRODUCT SPECIFICATION SHEET

EDI FlexAir[®] PermaCap[™]

Coarse Bubble Diffuser Unit

Greater unit capacity over other small diameter diaphragm coarse bubble diffusers at less cost

- Low capital and maintenance cost
- 5 inch diameter for greater air distribution
- Engineered air outlet orifices
- Non-clog design
- Durable ABS body & membrane retainer ring
- 3/8 inch or 3/4 inch NPT (male) connection
- UV Protection
- Advanced Technology EPDM Membrane
- Internal check valve to prevent entry of solids into piping
- Promotes fluid interaction with maximum bubble formation and dispersion
- Preferred mounting on bottom of air piping
- High airflow capacity
- Membrane interlock feature prevents blow out
- Optional UDM for non-threaded connections
- Units IN STOCK for immediate shipment

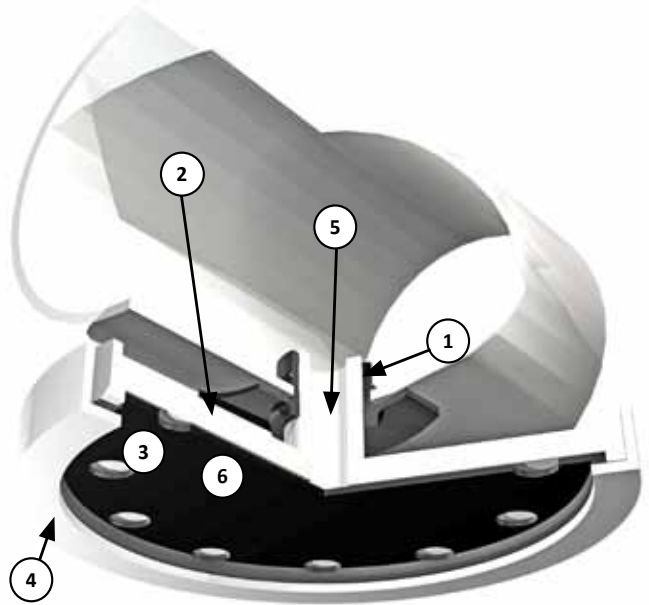

1. Threaded connector 3/4 inch NPT (male) Inlet
2. ABS Diffuser Body
3. Inlet Orifice
4. ABS Retainer Ring - 5" Diameter
5. Check Valve
6. Premium Quality EPDM Membrane



www.wastewater.com
Environmental Dynamics International

aeration for life™

PRODUCT SPECIFICATION SHEET

EDI PermaCap™ diffusers are ideal for aeration applications where intermittent coarse bubble operation is desired. PermaCap units are available with either 3/8 inch or 3/4 inch NPT threaded (male) inlet to allow quick and simple installation into threaded pipe applications. Optional UDM (Universal Diffuser Mount) is available for non-threaded applications. Units particularly well suited for single drop pipe installations in package treatment plants and channel aeration.

The diffuser assembly features a flexible membrane element that is configured to exclude solids during idle operations providing

long-term trouble free operation. The flexible membrane features a non-perforated area that is directly aligned with the air outlet port. During idle operation the membrane retracts and seals the air exit port reducing back flow into the unit. The membrane element is mechanically engaged with the diffuser assembly preventing the membrane from disengaging from the diffuser assembly.

The PermaCap is suitable for installation on bottom (preferred) of diffuser piping. PermaCap coarse bubble units offer great value as a low cost aeration/mixing solution.

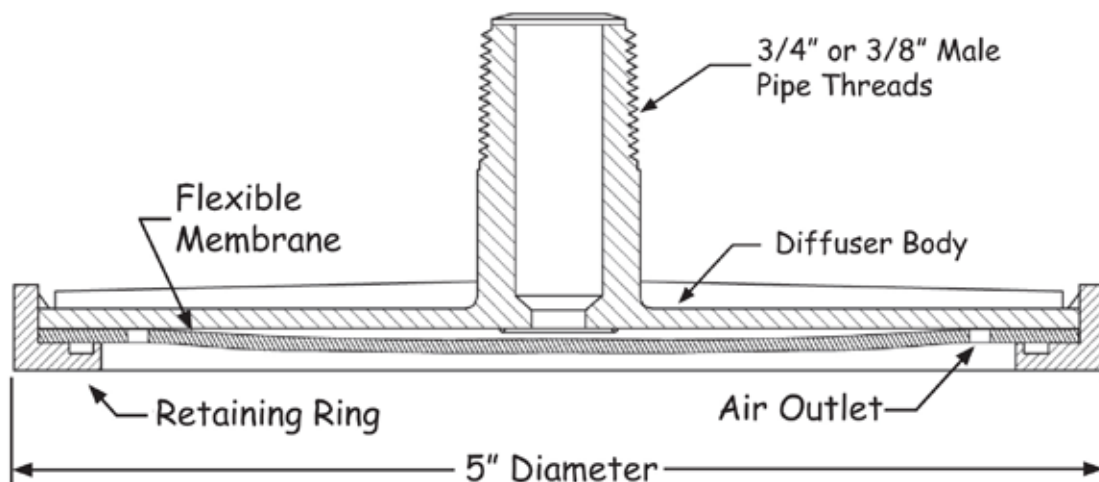

	Diffuser Type	Design Airflow		Overall Diameter		Active Surface Area		Dry Weight		Net Operating Buoyancy	
		scfm	m ³ /h	in	mm	ft ²	m ²	lb	kg	lb	kg
PermaCap (Coarse)	3/8" Orifice	2-20	2-32	5.00	127	0.13	0.012	0.19	0.087	0.040	0.018
	3/4" Orifice	2-20	2-32	5.00	127	0.13	0.012	0.20	0.091	0.049	0.022
PermaCap (Medium)	3/8" Orifice	1-8.0	1-13	5.00	127	0.13	0.012	0.19	0.087	0.040	0.018
	3/4" Orifice	1-8.0	1-13	5.00	127	0.13	0.012	0.20	0.091	0.049	0.022
PermaCap (Fine)	3/8" Orifice	0.5-2.0	0.5-3.2	5.00	127	0.13	0.012	0.19	0.087	0.040	0.018
	3/4" Orifice	0.5-2.0	0.5-3.2	5.00	127	0.13	0.012	0.20	0.091	0.049	0.022

- Optimum oxygen transfer efficiency is achieved when operating in the middle to low end of the airflow range. The approximate operating pressure of the diffuser at the mid-range is 5-10 inches (1.2-2.5 kPa).



Environmental Dynamics International
 5601 Paris Road • Columbia, MO 65202 USA
 +1 877.EDI.AIR8 (334.2478) +1 573.474.9456

For Parts Information:
parts@wastewater.com
www.diffuserexpress.com

For System Information:
systems@wastewater.com
www.wastewater.com