

PRODUCT SPECIFICATION SHEET

EDI FlexAir® Threaded Disc

Fine Pore Flexible Membrane Technology

FlexAir Disc diffuser incorporates EDI advanced membrane technologies for superior aeration performance, flexibility, and reliability

- Precision die cut openings for high oxygen transfer, uniform air release, and low operating pressure
- High capacity membrane option available for maximum airflow and low operating pressure
- Advanced technology premium quality membrane materials available in EPDM and other special polymer blends
- Triple check valve design prevents entry of liquid/solids into piping. Ideal for on / off applications
- Resistant to fouling and plugging for low maintenance
- Economical capital cost and ease of installation
- Rugged heavy duty construction
- Glass fiber reinforced polypropylene construction for maximum chemical, temperature, and UV resistance
- Mounts on any pipe material (PVC, ABS, CPVC, SS, etc.) or size with EDI Universal Diffuser Mount (UDM) or standard 3/4 inch FPT (female) connection
- Standard units IN STOCK for immediate shipment
- Patented EZSeal for quick hand tight seal

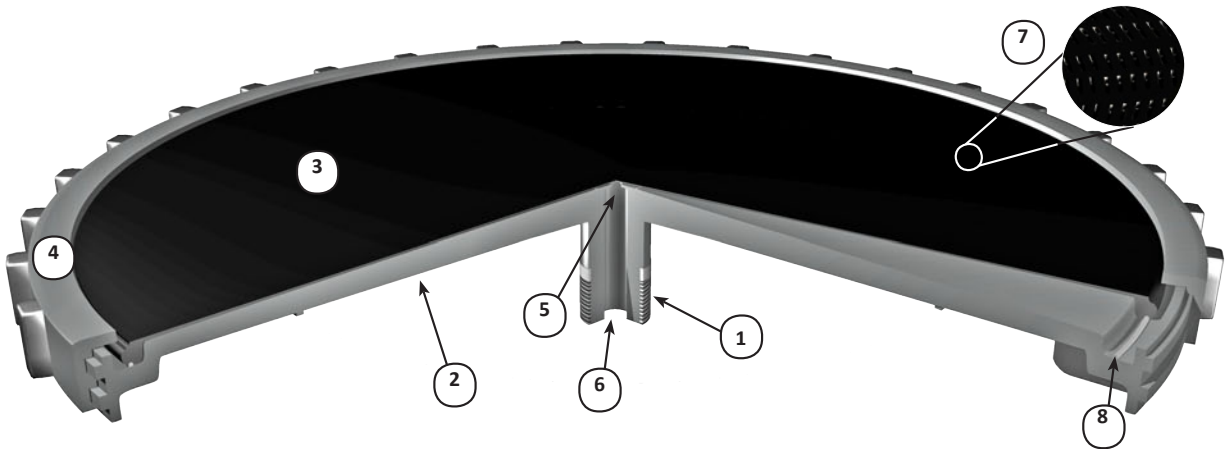

- | | |
|--|--------------------------------|
| 1. Threaded Connector
3/4 inch NPT (male) Inlet | 5. Primary Check Valve Feature |
| 2. Diffuser Body | 6. Air Inlet Orifice |
| 3. Flexible Membrane Media | 7. Die Cut Perforations |
| 4. Membrane Retainer Ring | 8. EZSeal™ |



www.wastewater.com
Environmental Dynamics International

Value Solutions
Since 1975

PRODUCT SPECIFICATION SHEET

EDI FlexAir® disc diffusers are fine pore, flexible membrane diffusers that provide operational flexibility with maximum oxygen transfer efficiency.

The FlexAir disc diffuser is provided with premium quality membrane materials that are engineered by the EDI Membrane Technologies division. EDI's proprietary membrane materials are engineered for superior product life. Multiple membrane perforations are available to optimize the performance of the diffuser for maximum operating efficiency,

air handling capacity, or operating pressure. An integral triple check valve feature prevents the backflow of liquid into the diffuser and piping.

The diffuser assembly is constructed of glass-fiber reinforced polypropylene for maximum performance. This material option offers greater mechanical and temperature capabilities than conventional PVC or CPVC products.

FlexAir disc diffusers may be mounted with the EDI Universal Diffuser Mount (UDM) 3/4 inch FPT (female) connection.

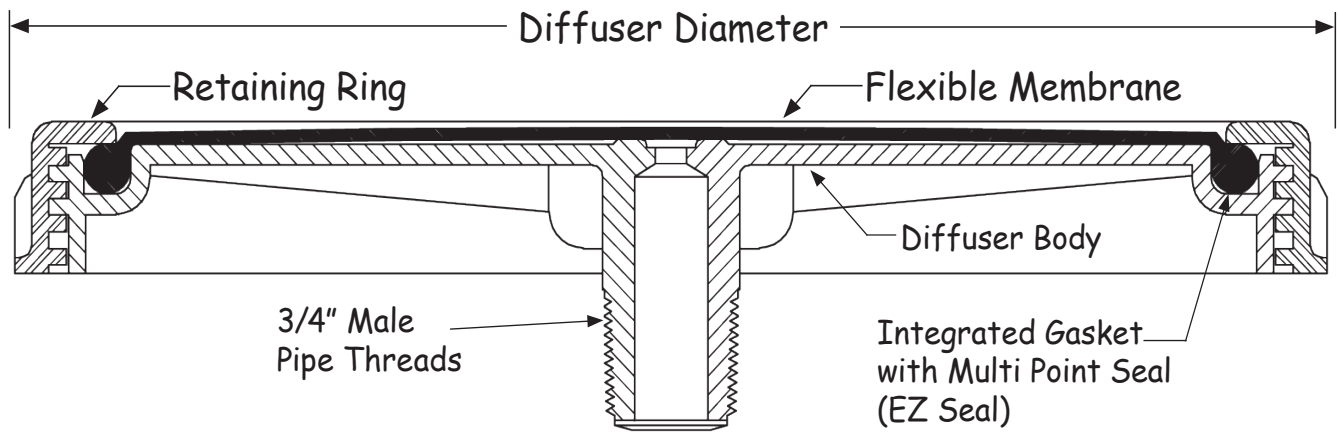

Diffuser Type	Design Airflow		Overall Diameter		Active Surface Area		Dry Weight		Net Operating Buoyancy	
	scfm	m ³ _N /h	in	mm	ft ²	m ²	lb	kg	lb	kg
7" Micro	0-3.0	0-4.8	9.0	229	0.26	0.024	1.1	0.53	1.0	0.46
7" High Cap	0-7.5	0-12	9.0	229	0.26	0.024	1.1	0.53	1.0	0.46
9" Micro	0-6.0	0-9.5	10.9	277	0.41	0.038	1.4	0.65	1.3	0.62
9" High Cap	0-10	0-16	10.9	277	0.41	0.038	1.4	0.65	1.3	0.62
12" Micro	0-10	0-16	13.8	351	0.73	0.068	2.3	1.1	2.2	1.0
12" High Cap	0-18	0-29	13.8	351	0.73	0.068	2.34	1.1	2.2	1.0

- Optimum oxygen transfer efficiency is achieved when operating in the middle to low end of the airflow range. The approximate operating pressure of the diffuser at the mid-range is 13 to 16 inches (3.2-4.0 kPa).
- Operating the unit at the high end of the range will result in reduced performance and increased operating pressure. Use the maximum airflow value for short term operations such as peak loads or system maintenance.



Environmental Dynamics International
 5601 Paris Road • Columbia, MO 65202 USA
 +1 877.EDI.AIR8 (334.2478) +1 573.474.9456

For Parts Information:
parts@wastewater.com
www.diffuserexpress.com

For System Information:
systems@wastewater.com
www.wastewater.com